

REV.	ECN NO.	DESCRIPTION	DRAW	APPD.	DATE
A	---				

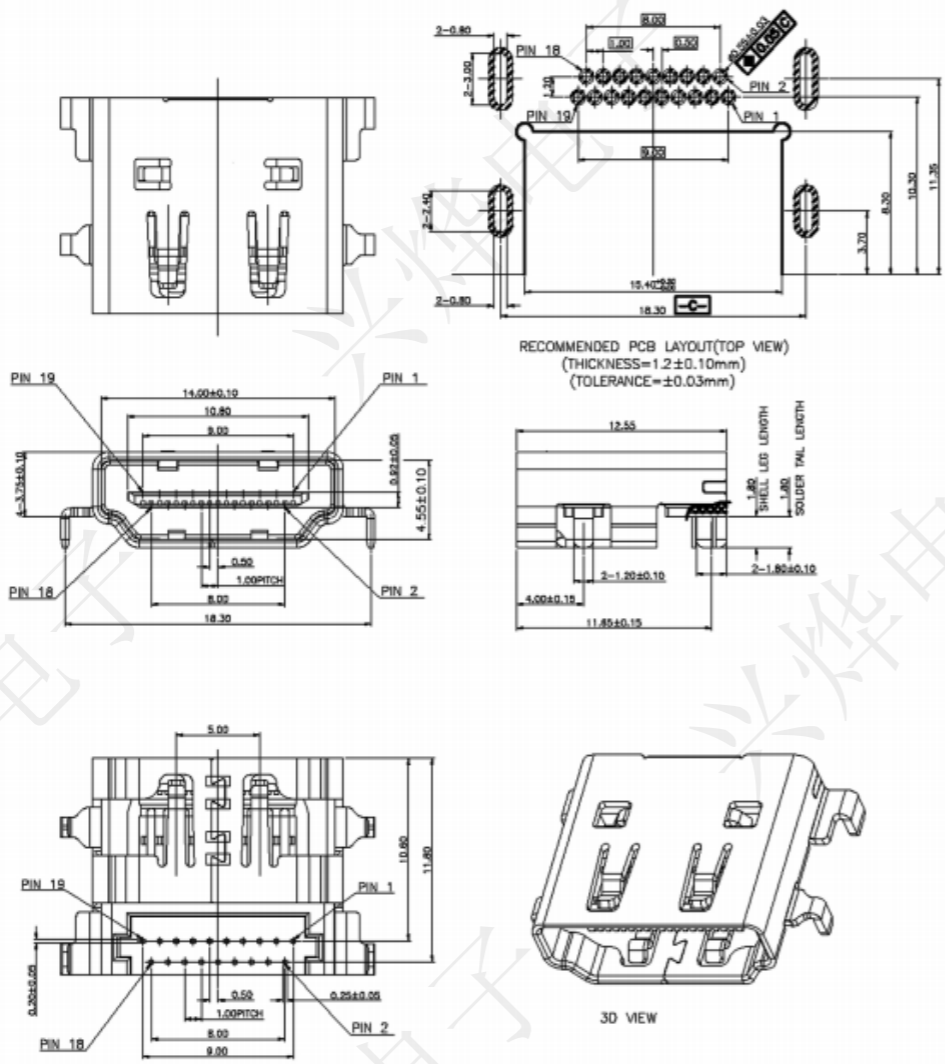

NOTES:

- MATERIAL SPECIFICATION
  - HOUSING: LCP+40% G.F BLACK UL94 V-0.
  - CONTACT: BRASS(C2680).
  - SHELL:BRASS(C2680).
- PLATING SPECIFICATION
  - CONTACT: NI50U" UNDER PLATED,GOLD FLASH PLATED ON THE FUNCTIONAL AREA OF CONTACT,GOLD PLATING OR TIN ON SOLDER AREA.
  - SHELL: NICKEL PLATED.
- MECHANICAL PERFORMANCE
  - INSERTION FORCE: 44.1N (4.5 KGF) MAX.
  - WITHDRAWAL FORCE: 4.9N~39.2N(0.5KGF~4.0KGF).
  - DURABILITY: 5000 CYCLES.
- ELECTRICAL PERFORMANCE
  - CURRENT RATING: 0.5A.
  - LLCR: CONTACT: 30 mΩ MAX(INITIAL), SHELL: 50 mΩ MAX(INITIAL).
  - INSULATION RESISTANCE:
    - UNMATED: 100 MΩ MIN. AT 500V DC.
    - MATED: 10 MΩ MIN. AT 150V DC.
  - DIELECTRIC WITHSTAND VOLTAGE:
    - 300V AC/60S(MATED), 500V AC/60S(UNMATED).
- IR REFLOW:  
THE PEAK TEMPERATURE ON BOARD SHALL BE MAINTAINED FOR 10 SECONDS AT 260±5°C.
- OPERATING TEMPERATURE RANGE: -20°C~85°C(WITHOUT LOSS FUNCTION).
- RoHS COMPLIANT OR HALOGEN FREE COMPLIANT.



受控文件

		Series Name :													
		Product Name : HDMI-19P四脚插沉板正向													
<table border="1"> <tr> <td colspan="2">TOLERANCE</td> <td rowspan="4">APPD: 陈爱光</td> </tr> <tr> <td>.XX ±0.30</td> <td>X° ±2°</td> </tr> <tr> <td>.XX ±0.20</td> <td>X° ±1°</td> </tr> <tr> <td>.XXX ±0.10</td> <td>XX° ±0.5°</td> </tr> <tr> <td>UNITS</td> <td>mm</td> <td>DRAW: 马洪飞</td> </tr> </table>		TOLERANCE		APPD: 陈爱光	.XX ±0.30	X° ±2°	.XX ±0.20	X° ±1°	.XXX ±0.10	XX° ±0.5°	UNITS	mm	DRAW: 马洪飞	Part NO: HDMI2007	
		TOLERANCE			APPD: 陈爱光										
.XX ±0.30	X° ±2°														
.XX ±0.20	X° ±1°														
.XXX ±0.10	XX° ±0.5°														
UNITS	mm	DRAW: 马洪飞													
		SCALE	SHEET	REV.											
		1:1	1/1	A1											

REV.	ECN NO.	DESCRIPTION	DRAW	APPD.	DATE
A	---				

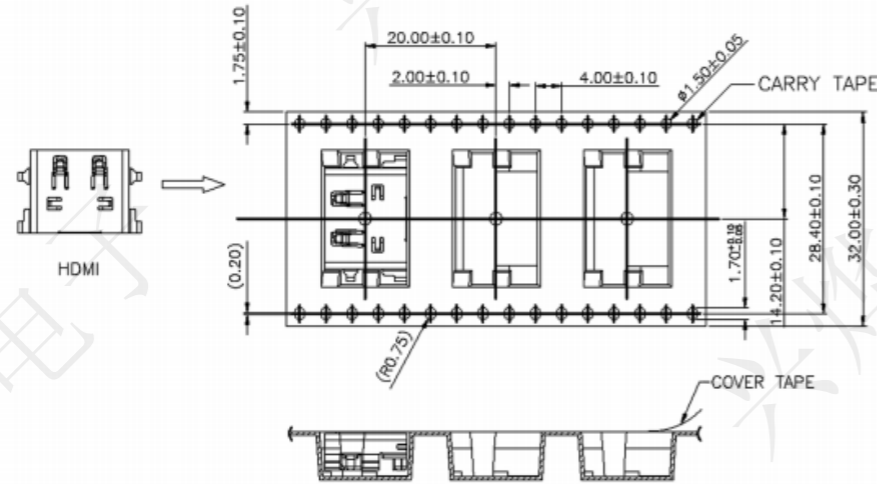
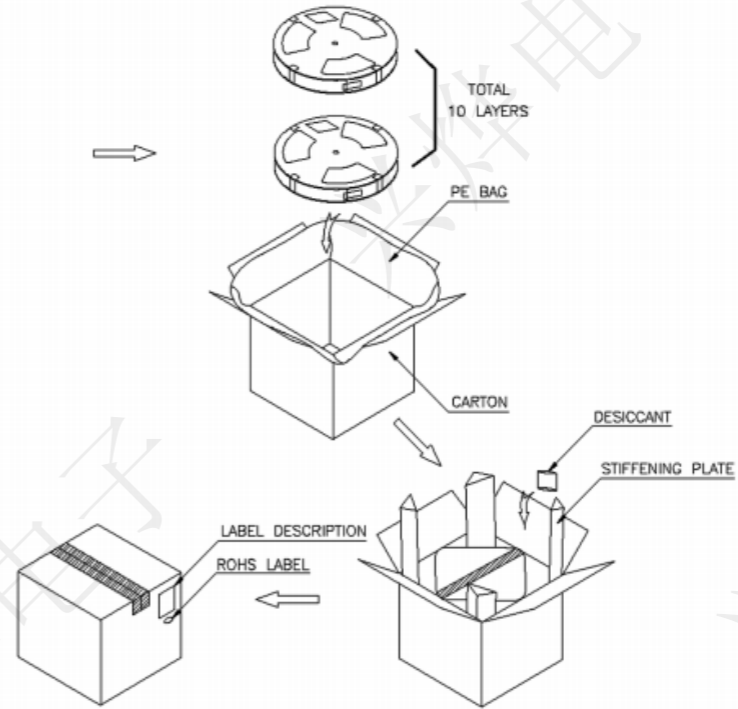
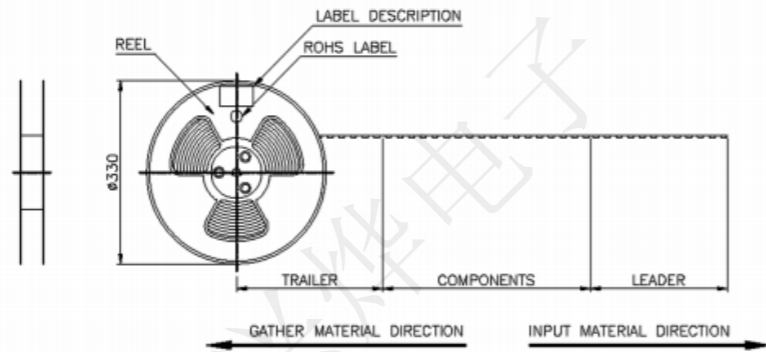

Notes:  
 1. THE START AND END OF EACH REEL, BASED ON THE ACTUAL QUANTITY, RESERVED 5--15PCS SPACE;  
 2. COVER TAPE AND CARRY TAPE PEEL: 10g~130g; PEEL DEG.:165°~175°;  
 PEEL SPEED: 250~300mm/min;  
 3. QTY: 500PCS/REEL, 10REEL/CARTON, TOTAL 5000PCS/CARTON;

<b>深圳市兴烨电子有限公司</b> ShenZhen XingYe Electronics co., Ltd		Series Name :		
		Product Name : HDMI-19P四脚插沉板正向		
TOLERANCE		Part N0: HDMIT2007		
X.X ±0.30	X.° ±2°	APPD: 陈爱光		SCALE SHEET REV. 1:1 1/1 A1
.XX ±0.20	.X° ±1°	CHED: 施立敏		
.XXX ±0.10	.XX° ±0.5°	DRAW: 马洪飞		
UNITS	mm			