

REV.	ECN NO.	DESCRIPTION	DRAW	APPD.	DATE
A	---				

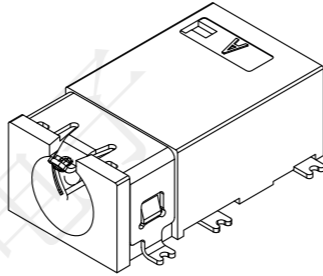

3D VIEW

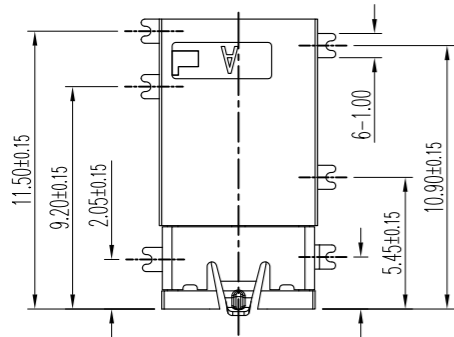
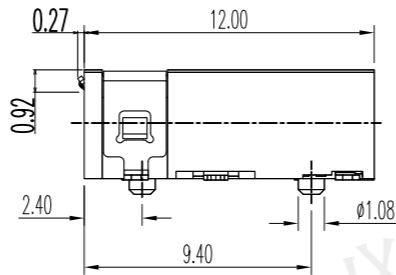
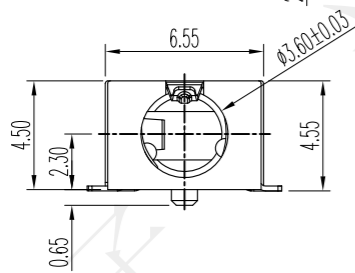

- CONTACT CURRENT RATING: 1A.
- CONTACT RESISTANCE: 50 mΩ MAX.;
- INSULATION RESISTANCE: 1000Ω MIN.;
- DIELECTRIC WITHSTANDING: 500V AC MIN.;
- DURABILITY: 5,000 CYCLES MIN.;
- CONNECTOR MATING FORCES: 30N MAX.;
- CONNECTOR UNMATING FORCES: 3N MIN.;

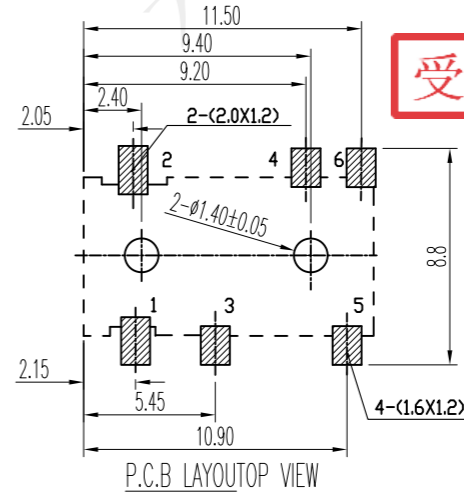

受控文件

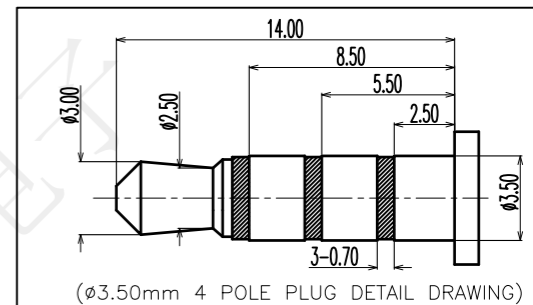
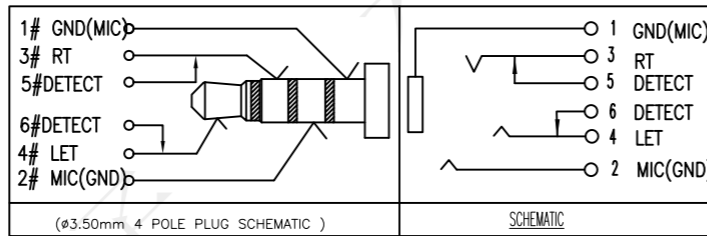
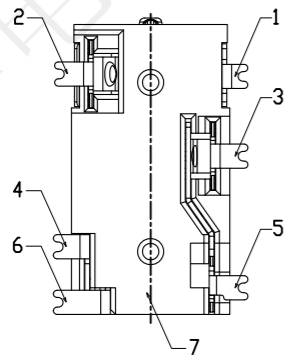

ITEM	NAME	Q'TY	DESCRIPTION	NOTE
7	HOUSING	1	HIGH TEMPERATURE PLASTIC COLOR BLACK	
6	TERMINAL 6#	1	BRASS; NICKEL UNDER PLATING OVERALL,GOLD FLASH PLATING ON SOLDER AREA	T=0.20mm
5	TERMINAL 5#	1	BRASS; NICKEL UNDER PLATING OVERALL,GOLD FLASH PLATING ON SOLDER AREA	T=0.20mm
4	TERMINAL 4#	1	STAINLESS STEEL; NICKEL UNDER PLATING OVERALL,GOLD FLASH PLATING ON SOLDER AREA ;GOLD FLASH PLATING ON CONTACT AREA	T=0.20mm
3	TERMINAL 3#	1	PHOSPHOR BRONZE; NICKEL UNDER PLATING OVERALL,GOLD FLASH PLATING ON SOLDER AREA ;GOLD FLASH PLATING ON CONTACT AREA	T=0.20mm
2	TERMINAL 2#	1	PHOSPHOR BRONZE; NICKEL UNDER PLATING OVERALL,GOLD FLASH PLATING ON SOLDER AREA ;GOLD FLASH PLATING ON CONTACT AREA	T=0.20mm
1	TERMINAL 1#	1	PHOSPHOR BRONZE; NICKEL UNDER PLATING OVERALL,GOLD FLASH PLATING OVERALL;	T=0.20mm

**深圳市兴烨电子有限公司**  
ShenZhen XingYe Electronics co., Ltd

TOLERANCE

X.X	±0.30	X.°	±2°
XX	±0.20	.X.°	±1°
XXX	±0.10	.XX.°	±0.5°

UNITS mm

APPD: 陈爱光  
CHED: 施立敏  
DRAW: 马洪飞

Series Name :

Product Name : PJ-35A063 无头贴片编带

Part NO: PJX21029

SCALE	SHEET	REV.
1:1	1/1	A1